

A MWO Scripting Example to Generate a RLGC(K) Model for Signal Integrity Analysis

- Joost ter Laak
- Consultant
- <http://www.jtl-engineering.nl>



JTL Engineering B.V.

How to model a package?

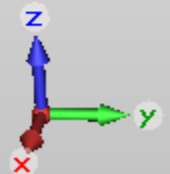
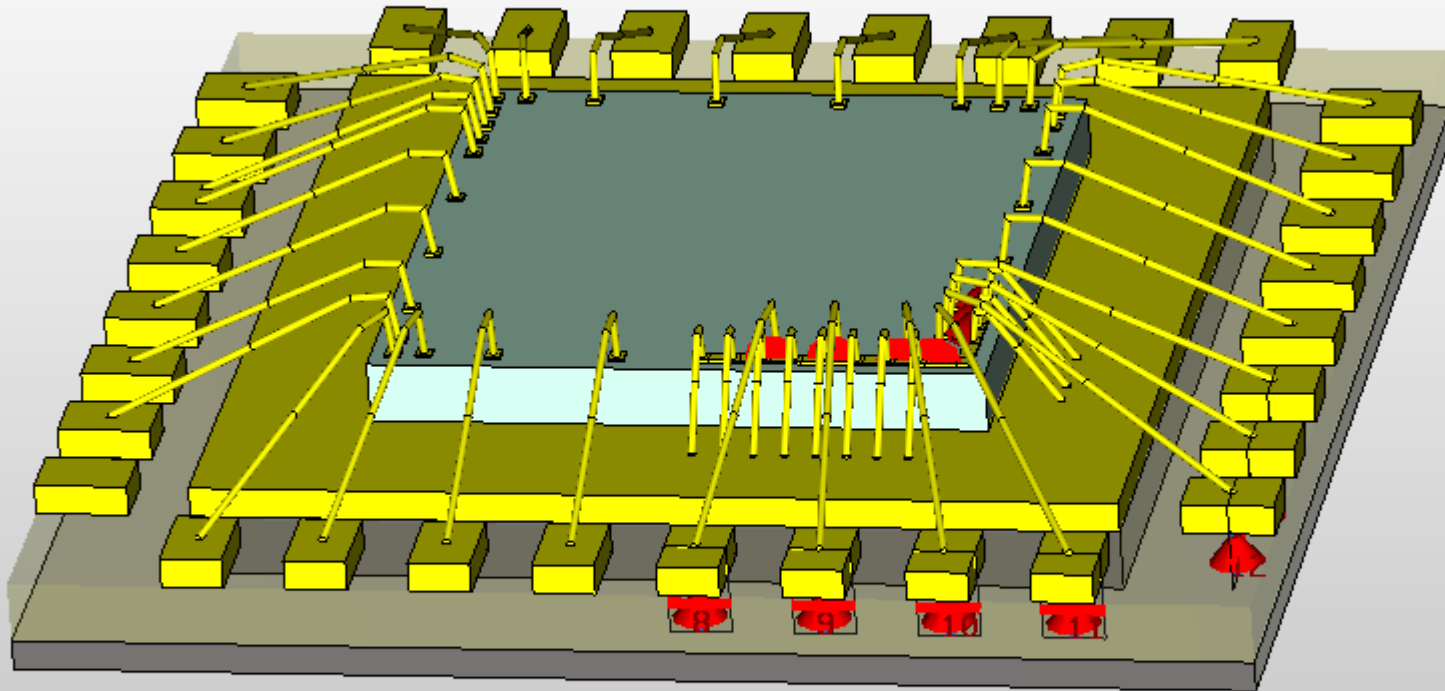

A LRC model is sufficient in a small bandwidth

MUC7
ID=M1
L1=0.856 i H
R1=0.181 O i m
L2=0.857 i H
R2=0.148 O i m
L3=0.902 i H
R3=0.171 O i m
L4=1.05 i H
R4=0.274 O i m
L5=1.056 i H
R5=0.25 O i m
L6=0.914 i H
R6=0.184 O i m
L7=0.866 i H
R7=0.197 O i m
K1_2=0.147
K1_3=0.05
K1_4=0.028
K1_5=0.012
K1_6=0.007
K1_7=0.005
K2_3=0.144
K2_4=0.067
K2_5=0.026
K2_6=0.015
K2_7=0.008
K3_4=0.234
K3_5=0.076
K3_6=0.038
K3_7=0.02
K4_5=0.158
K4_6=0.071
K4_7=0.035
K5_6=0.227
K5_7=0.089
K6_7=0.201

C1=.1
C2=.026

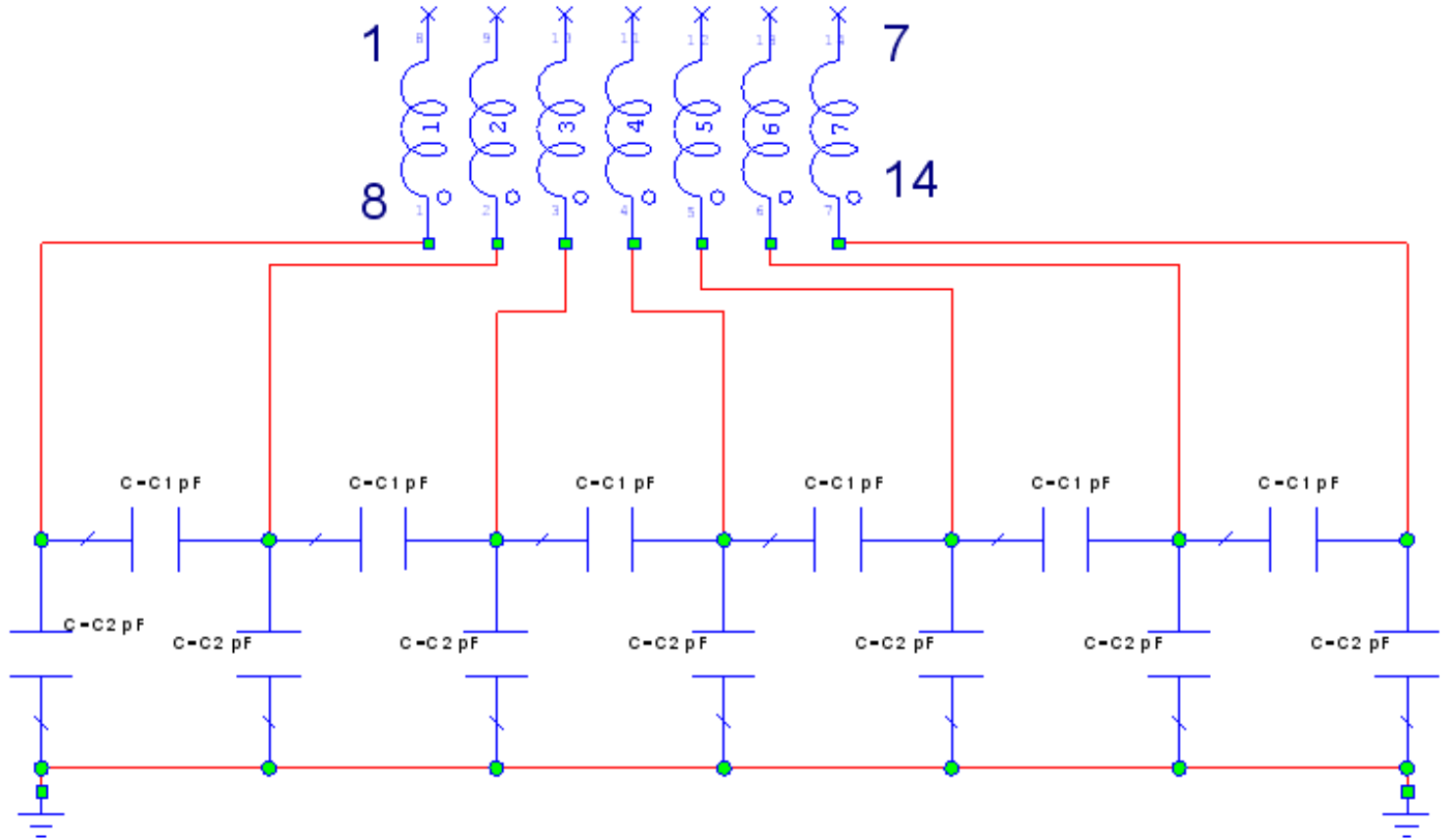

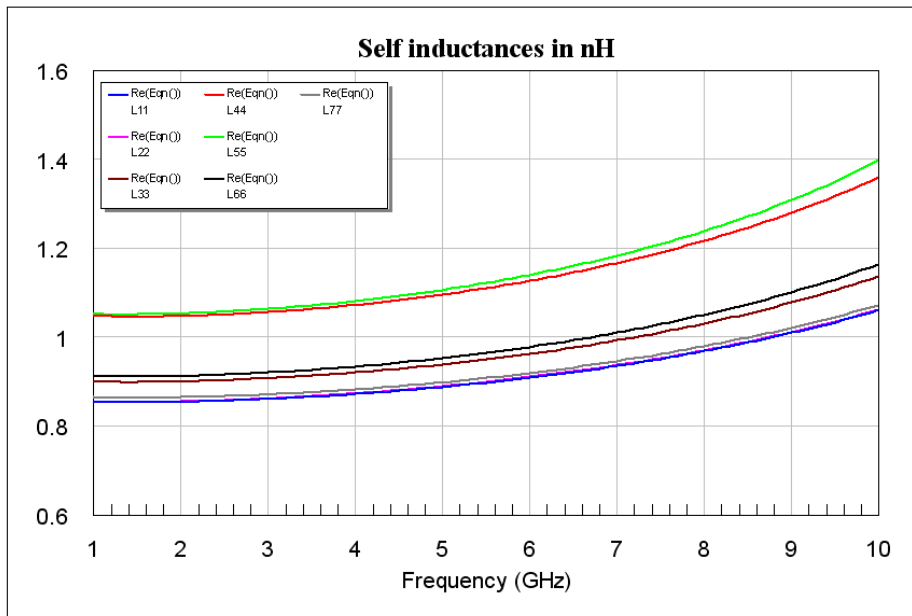

At higher frequencies the wires can not longer be modeled accurately by a single inductance due to the delay

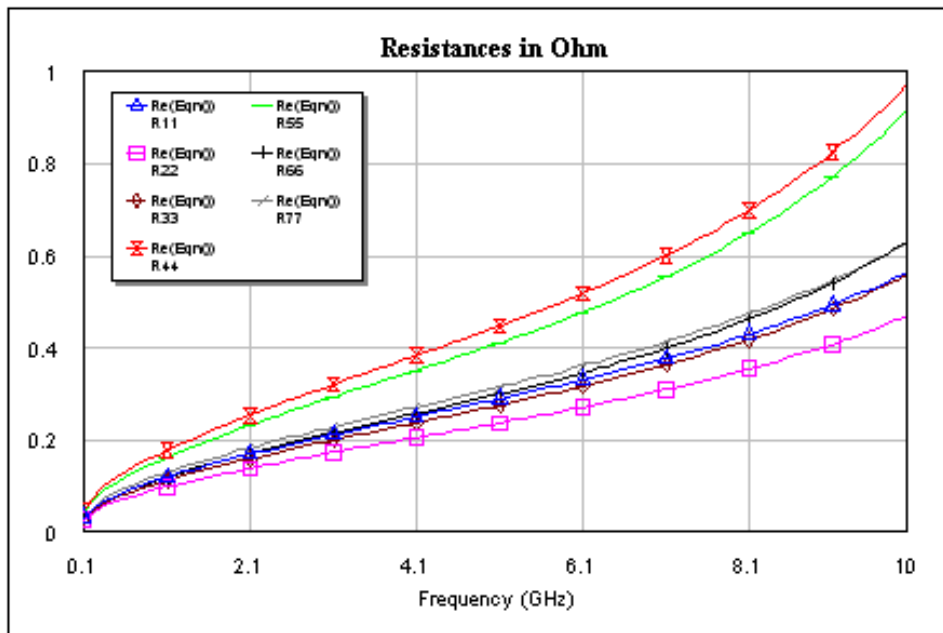

Resistance scales approximately linear with frequency

Sqrt due to skin effect * Sqrt due to delay/transformation

A coupled RLGC model handles the delay much better

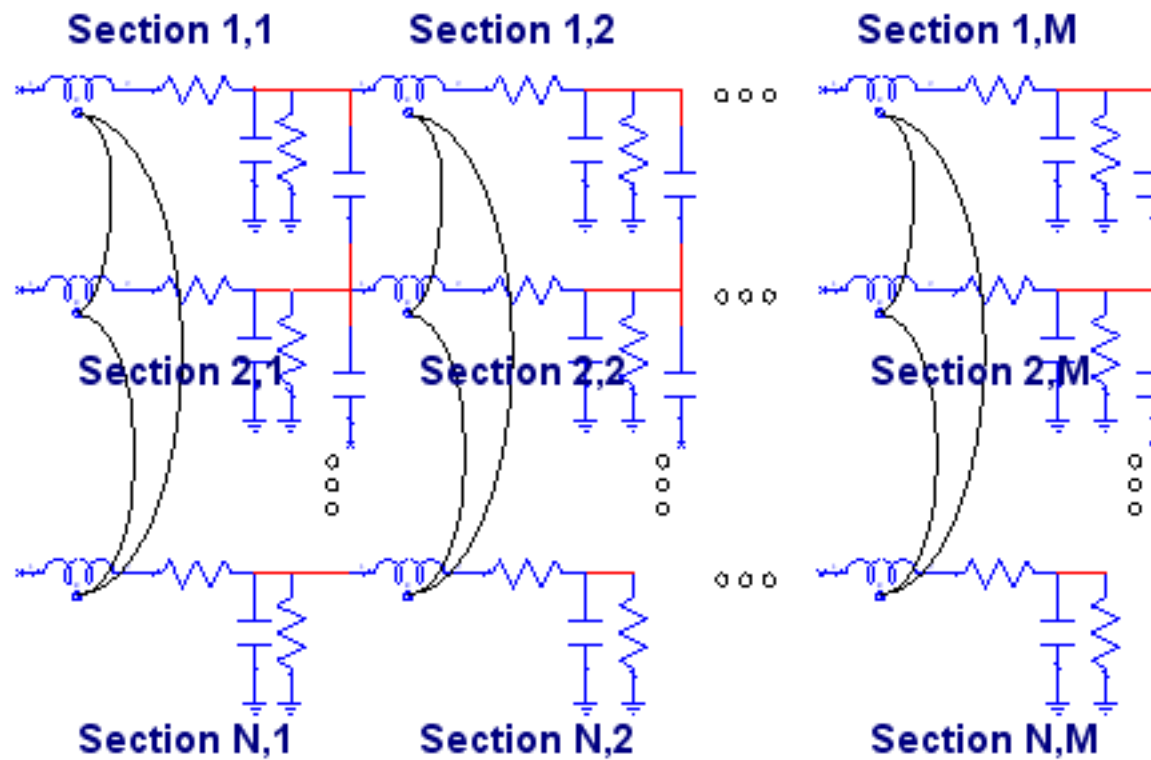

Example: BGA with a 32 bits digital bus

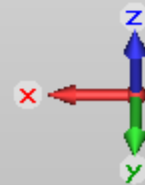
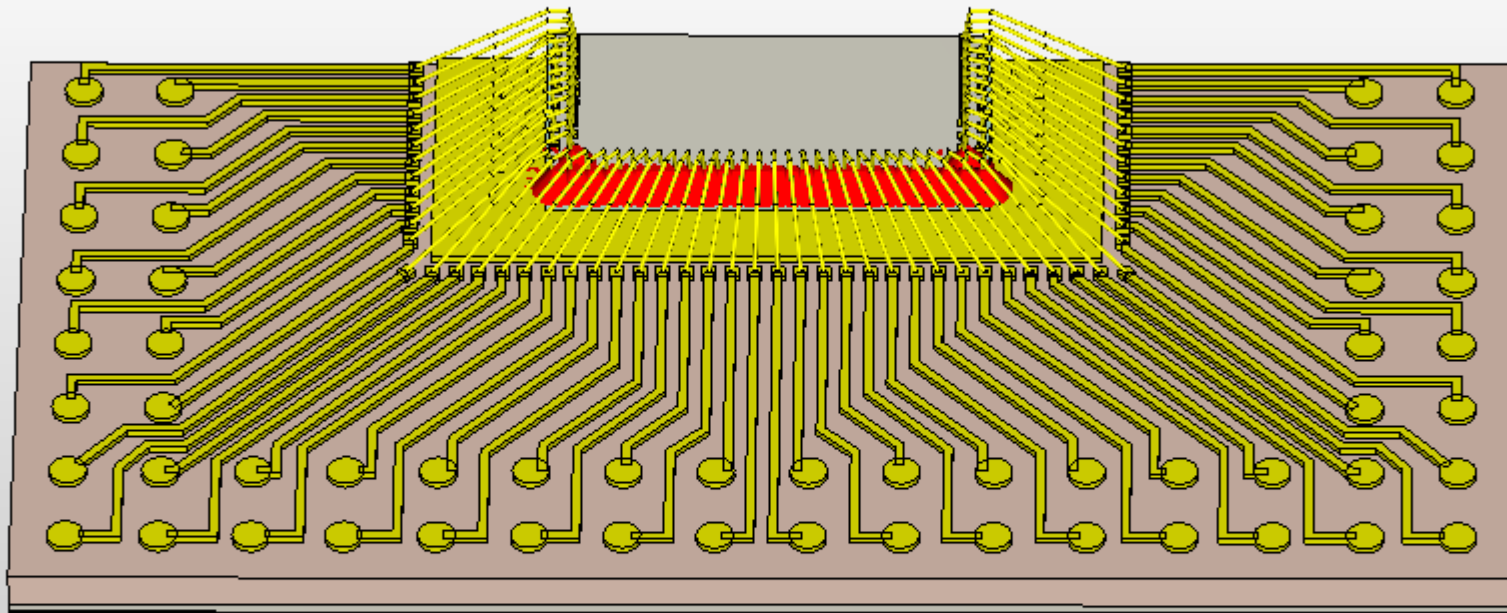

Digital signals have a large bandwidth.

Square wave consist of a large number of odd harmonics

$$V(t) = \frac{4}{\pi} \sum_{n=1,3,5\dots}^{\infty} \frac{1}{n} \sin(2\pi nt)$$

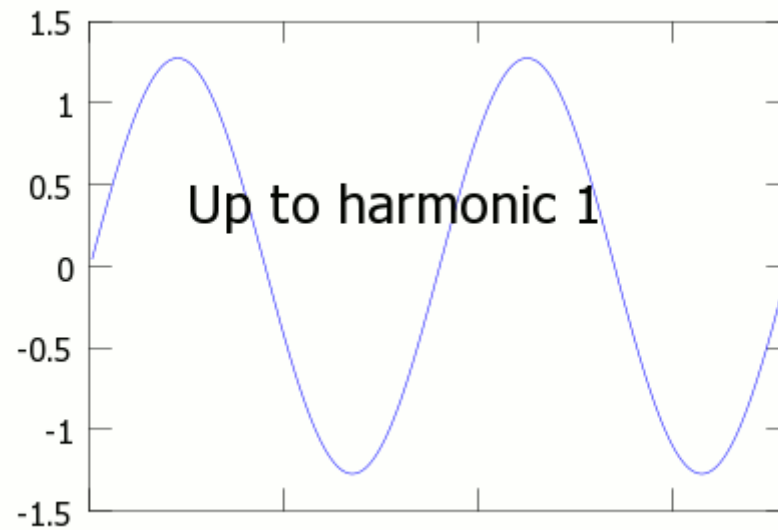

A RC type filtering causes a delay in higher harmonics, leading to larger rise and fall times

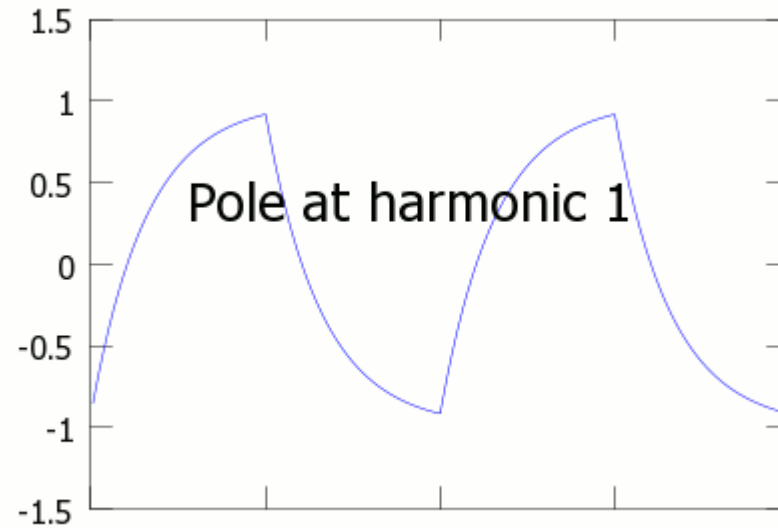

How to calculate the model parameters ?

R
L
G
C
Kij
Cm

The Telegrapher's equations describe a transmission line

$$Z_0 = \sqrt{\left(\frac{R + j\omega L}{G + j\omega C}\right)}$$

characteristic impedance [Ω]

$$y = \sqrt{\left((R + j\omega L)(G + j\omega C)\right)}$$

propagation constant [dimensionless]

$$R = \text{real}(y Z_0)$$

$$L = \text{imag}(y Z_0) / \omega$$

$$G = \text{real}(y / Z_0)$$

$$C = \text{imag}(y / Z_0) / \omega$$

Setup to simulate the magnetic coupling

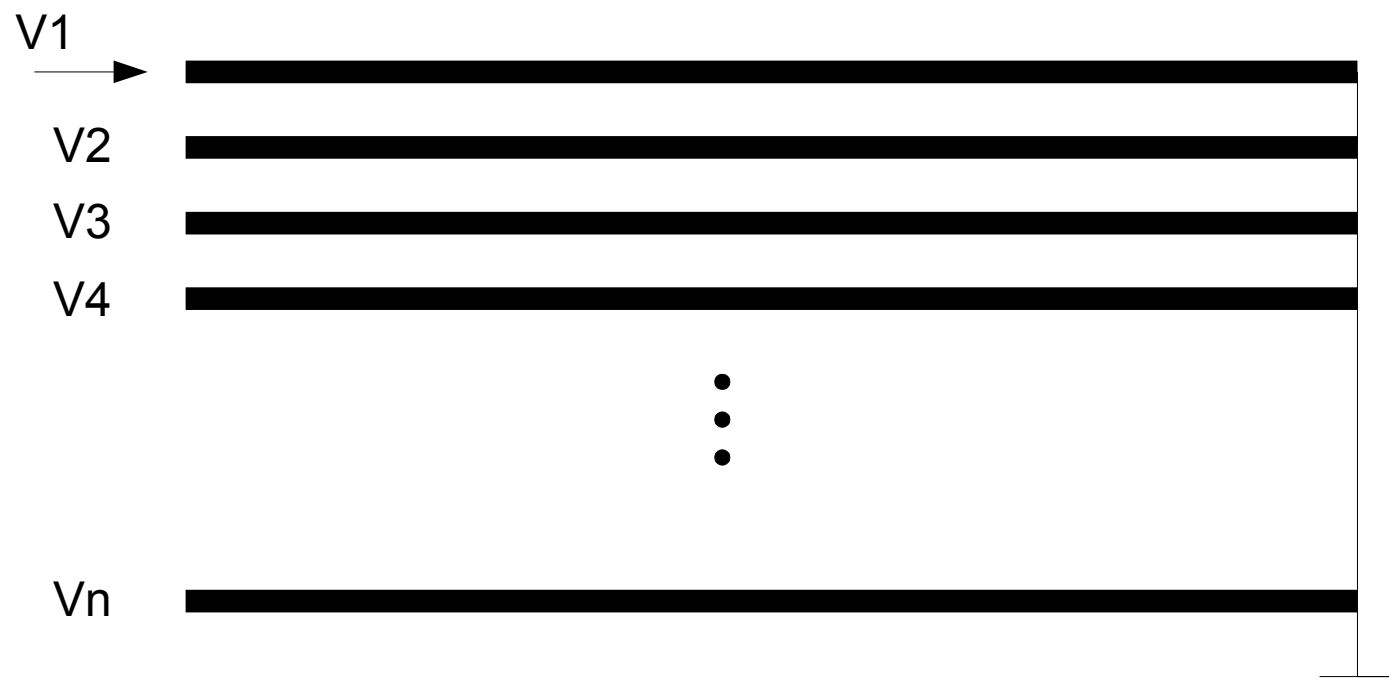

Extracting a two port from the 64-port, 32 times needed

1 →

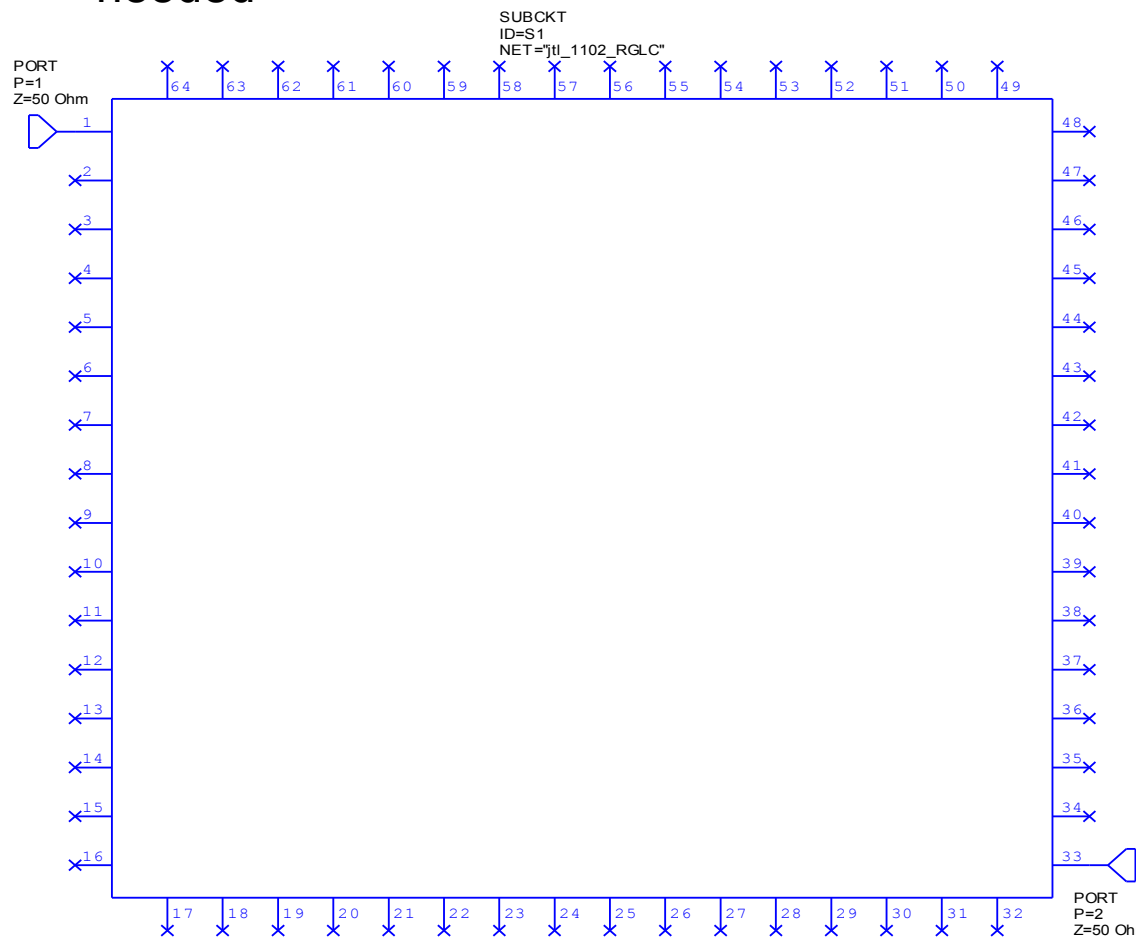

← 2

Setup to calculate the induced voltages, 32 times needed

V_{in} →

V_{out} ←

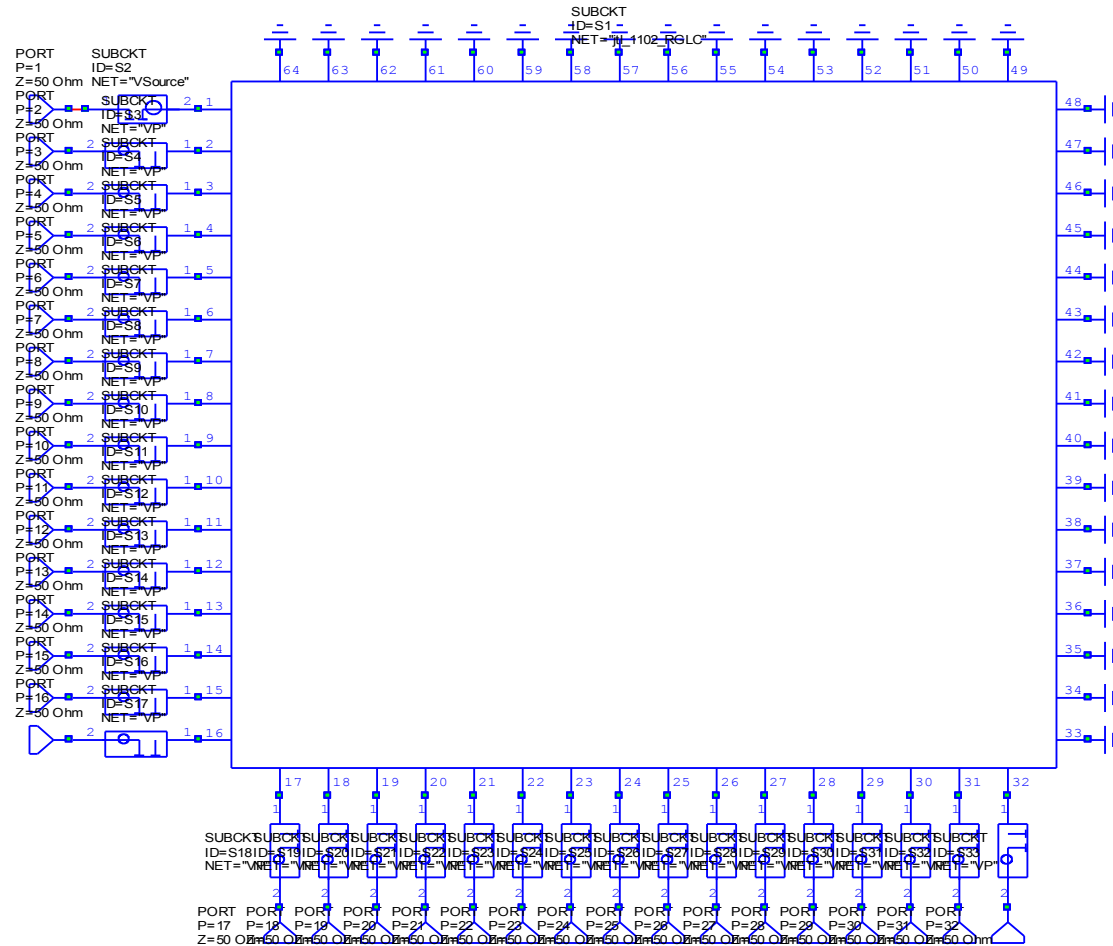

Setup to calculate the couple capacitance, 31 times needed

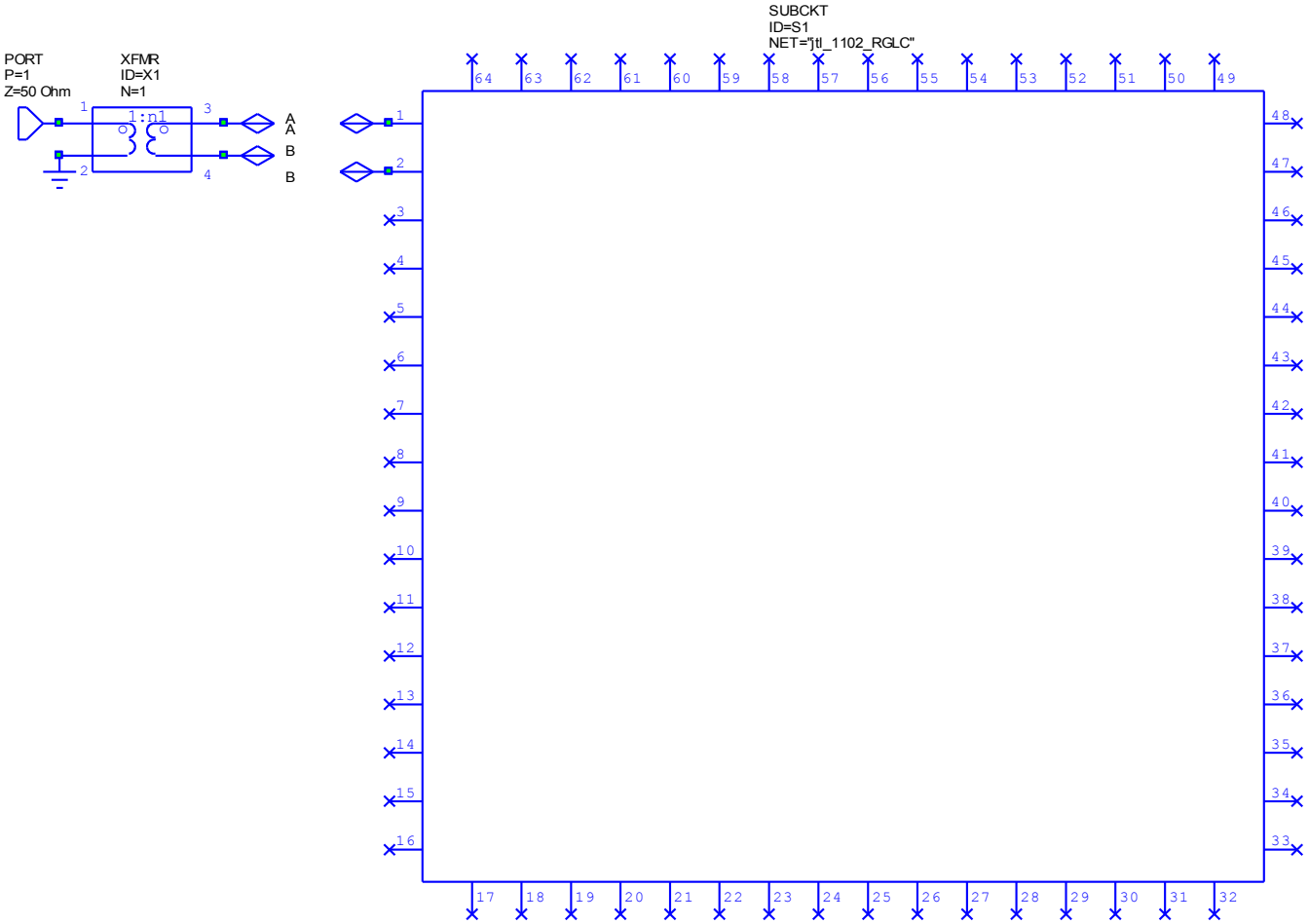

Starting from a N port s-parameter set, how do I create the necessary schematics?

In this example N is 64, I need $3 * N/2 = 96$ schematics

In MWO scripts can be written in a Visual Basic compatible scripting editor to automate tasks.

I have written a MWO script to:

- 1 create the $N/2$ two port schematics
- 2 create the $N/2$ schematics for the magnetic coupling
- 3 create the $N/2 - 1$ schematics for the electric coupling
- 4 set up all graphs to hold the simulation data
- 5 run the circuit solver
- 6 read out the graphs
- 7 calculate the R L G C K Cm parameters
- 8 create a RLGC schematic
- 9 create a spice netlist

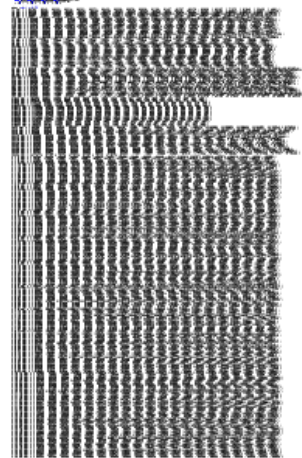
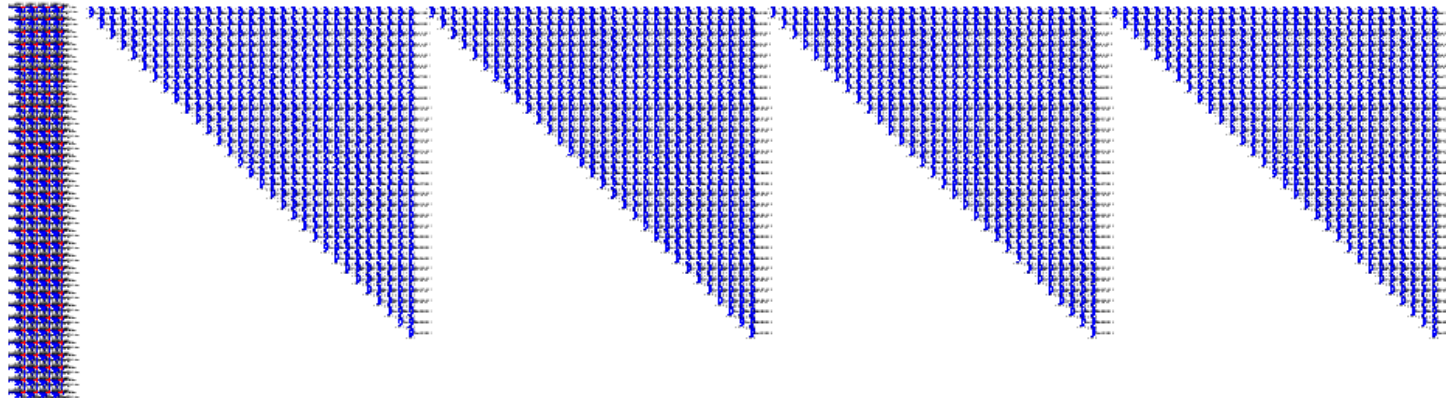

The created RLGC schematic contains
636 R,L,G and C's
1932 K-factors

The inductance L (of a single section) is nearly constant over frequency

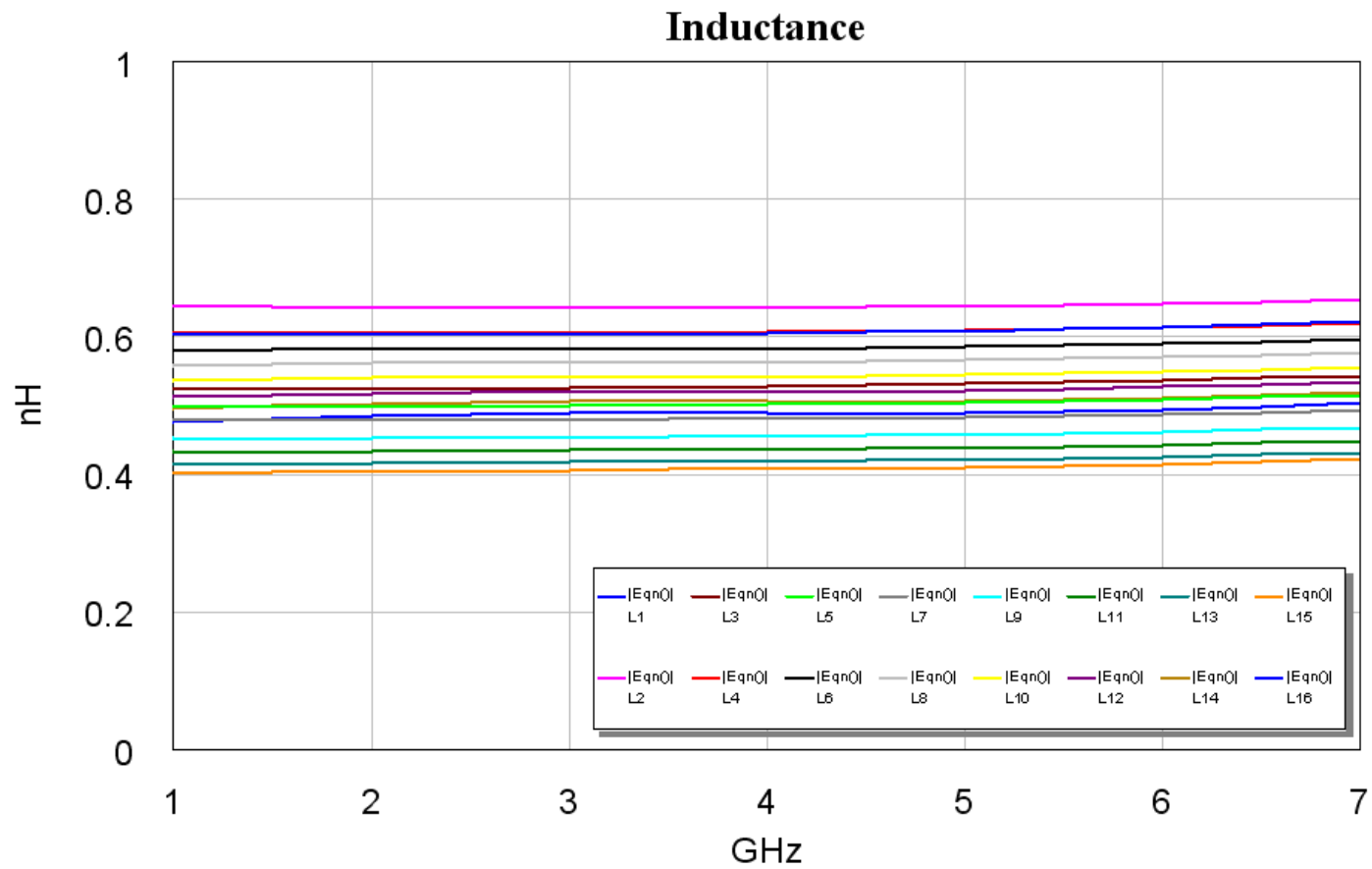

The capacitance C shows a little frequency behavior which is due to the package pin and via which are taken as a part of the transmission line

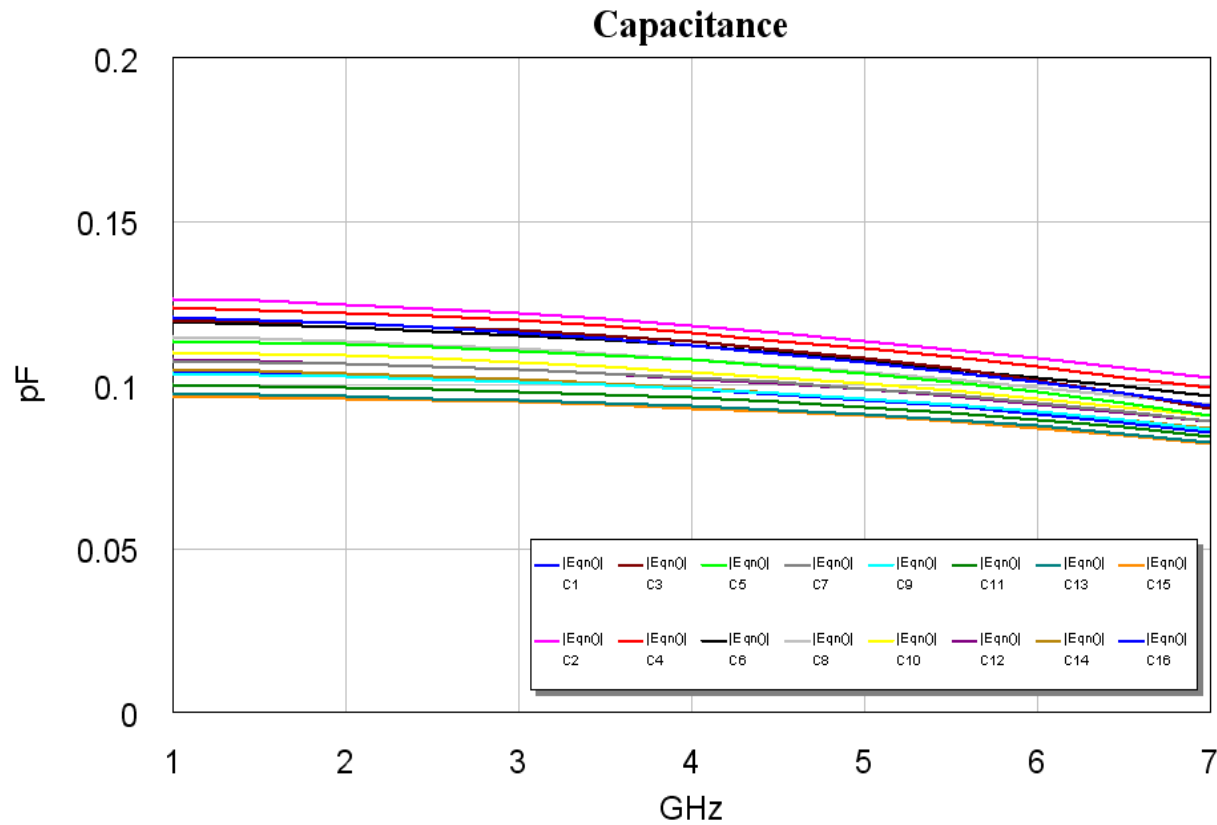

The resistance R is (still) strong frequency dependent

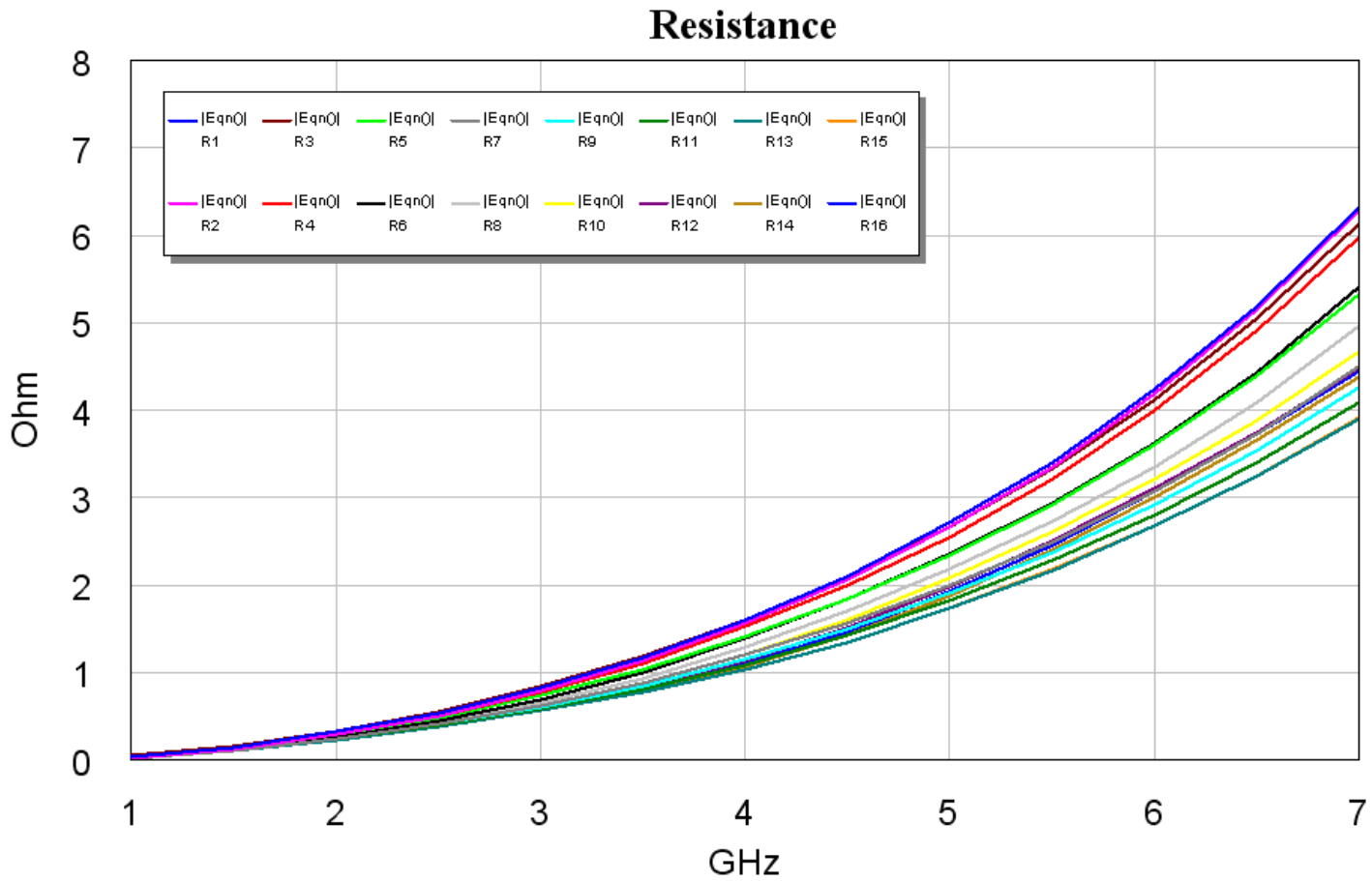

The K-factors are frequency independent.

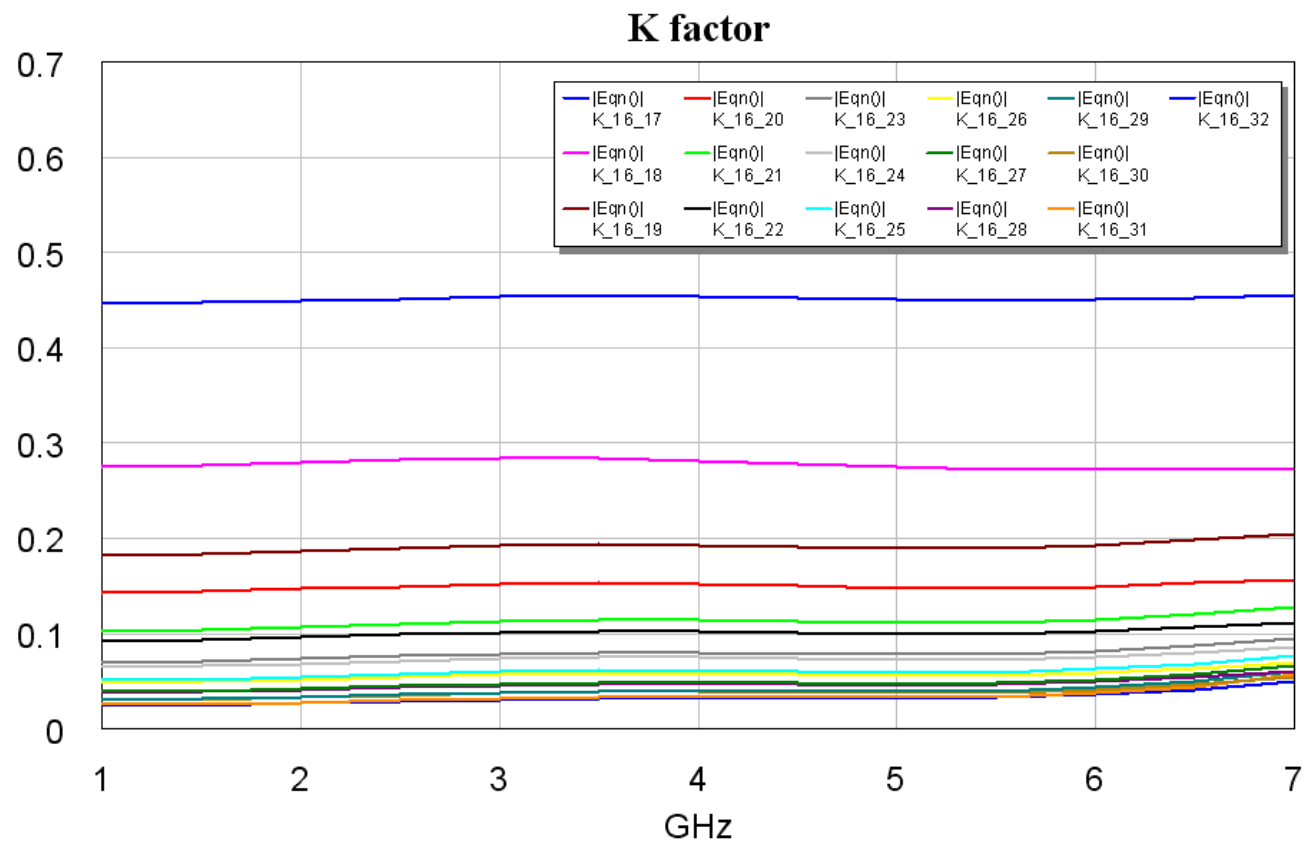

Using the generated coupled RLGC model in a time domain simulation (spice) to check the model against the 3D field solver

Red is the 3D field solver
Green is the spice model

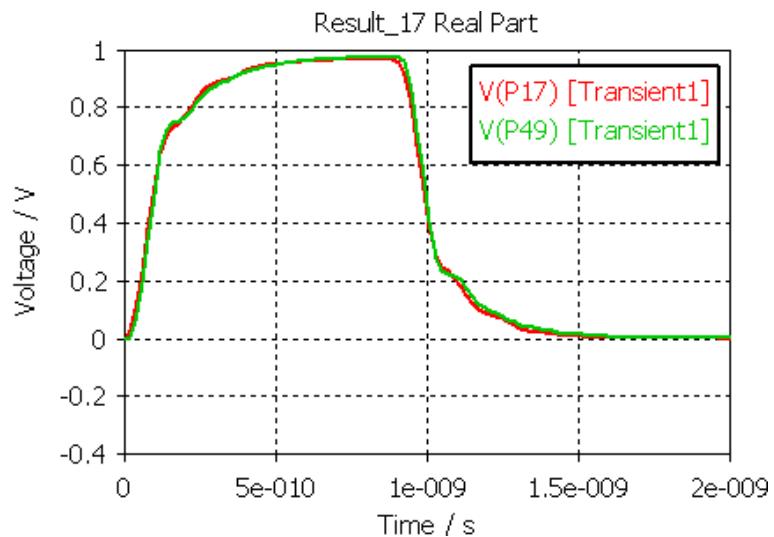

A 1-0 on a odd bit-line

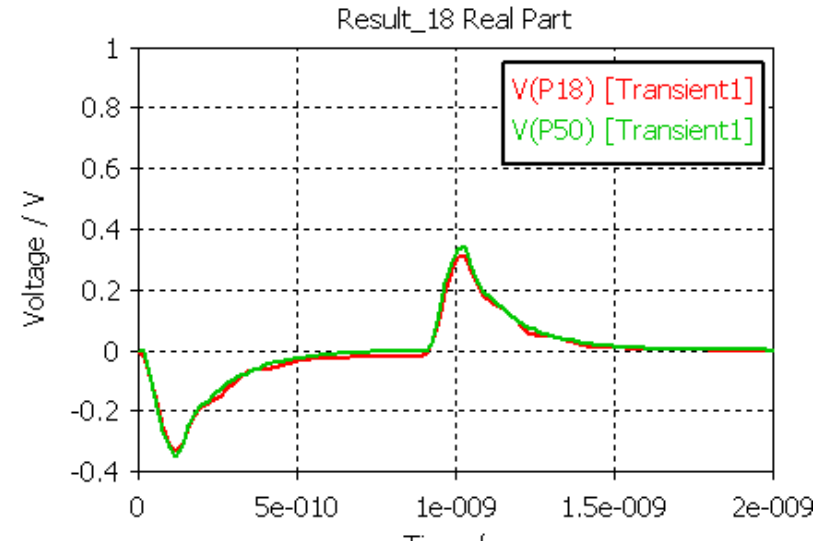

A 0-0 on a even bit-line, the spikes are induced by the odd bit-lines